



ELECTRONICS CORPORATION OF INDIA LIMITED

**A Govt. of India (Dept. of Atomic Energy) Enterprise
ECIL (Post), Hyderabad – 500062, Telangana, India**

ELECTRONIC WARFARE DIVISION - EWD

REQUEST FOR QUOTATION

Tender No: CNSG09-8197

Details of RFQ

| | | | |
|-------------------------------------|---|---|-----------|
| Scope of Supply | : | Supply of Fiber Optic Cables | |
| Method of Tender | : | Two Part Bid | |
| Important Dates: | | | |
| | | Date | Time |
| Tender Publishing Date | : | 16-06-2025 | 15:30 Hrs |
| Tender Document Download Start Date | : | 16-06-2025 | 15.30 Hrs |
| Last Date of Receiving Queries | : | 21-06-2025 | 17:00Hrs |
| Pre-Bid Meeting Date | : | 26-06-2025 | 11.00 Hrs |
| Replies to Queries by | : | 30-06-2025 | 17:00Hrs |
| Due Date for Submission | : | 07-07-2025 | 15:00 Hrs |
| Opening of Techno-Commercial Bids | : | 07-07-2025 | 15:30Hrs |
| Opening of Price Bids | : | Will be informed later | |
| Contact Person Details | : | In-Charge MMD, CNSG Group, Electronics Corporation of India Limited ECIL (P.O), Hyderabad – 500 062 Tel Nos.040-27182725,27182392 E Mail ID: cndmmd@ecil.co.in | |



ELECTRONICS CORPORATION OF INDIA LIMITED
A Govt. of India (Dept. of Atomic Energy) Enterprise
ECIL (Post), Hyderabad – 500062, Telangana, India

| | | |
|------------|--|---|
| Telephone: | 040-27182725/2392 | In-Charge MMD, CNSG Group, Electronics Corporation of India Limited ECIL (P.O), Hyderabad – 500 062 Telangana, India. |
| Mobile: | 9440808020 | |
| e-Mail: | cndmmd@ecil.co.in | |
| Fax: | 040-27121606 | |

Tender No:ECIL/CNSG/PUR/09/8197

Date:16.06.2025

Dear Sir,

Invitation of Bid for Supply of Fiber Optic Cables:

1. Electronics Corporation of India Ltd., (ECIL) a Government of India undertaking with its registered office at ECIL P.O, Hyderabad – 500062, invites Bids through e-Procurement portal (<https://etenders.ecil.co.in>) for supply of items listed in PART-II of this RFQ. This RFQ is being issued on Two Part Bid basis. The firm has to upload Techno-Commercial Bid in the Technical Part of the online tender and Price Bid in the financial offer part of the online tender.
2. The address and contact numbers for sending documents or seeking clarifications regarding this RFQ are given below.

| | |
|-------------------|---|
| Contact details : | For Technical clarifications: Name: N.VANAJA, DGM Tel Nos.040-27182743 Email: n_vanaja@ecil.co.in |
| | For other RFQ related clarifications: In-Charge MMD, CNSG Group Tel Nos. 040-27182725/2392 Email: cndmmd@ecil.co.in |
| | For eProcurement portal related clarifications: Help Desk No.: 040-27186294/6652/2273 Email: etendering@ecil.co.in |

3. This RFQ is divided into five Parts as follows:

| Sl. No. | Sections | Document Description | Page No. |
|---------|---------------|--|----------|
| (a) | Part I | General Information and Instructions for the Bidders | 4-7 |
| (b) | Part II | Essential Details of Items Required | 8-9 |
| (c) | Part III | Standard Terms and Conditions | 10-17 |
| (d) | Part IV | Special Terms & Conditions | 18-23 |
| (e) | Part V | Evaluation Criteria | 24-25 |
| (f) | Annexure-A.1 | Scope of Supply for Fiber Optic Cables | 26 |
| (g) | Annexure- A.2 | Technical Specifications | 27-30 |
| (h) | Annexure-B | Bid Security Declaration Form | 31 |
| (i) | Annexure-C | Self-Declaration by the bidder (In case bidder is Start-Up | 32 |

| | | Entity) | |
|-----|------------|---|-------|
| (j) | Annexure-D | Pre-Bid Meeting queriesFormat | 33 |
| (k) | Annexure-E | Eligibility Declarations | 34-36 |
| (l) | Annexure-F | Performance Bank Guarantee Format | 37-38 |
| (m) | Annexure-G | Restrictions under Rule 144(xi) of GFR 2017 | 39-41 |
| (n) | Annexure-H | Purchase Preference to Make in India | 42-45 |

4. This RFQ is being issued with no financial commitment and ECIL as a Buyer reserves the right to change or vary any part thereof at any stage. Buyer also reserves the right to withdraw the RFQ, should it become necessary at any stage without assigning any reason, whatsoever. ECIL shall have no liability for above mentioned actions.

Thanking you,

Yours faithfully,

For Electronics Corporation of India Limited

Encl.: RFQ Parts I to V and Annexure A to H.

Part I – General information and Instructions for the Bidders

| Particulars | Sl. No. | Terms and Conditions | Compliance required | (Yes/No) with Deviation if any |
|---------------------------------------|---------|---|---------------------|--------------------------------|
| Due Date: | 1 | <u>Last Date and Time for Uploading the Bids: (15:00Hrs on 07.07.2025)</u> Bids should be submitted by due date and time through e-procurement portal of ECIL for Supply of items mentioned in Part II of RFQ. | Noted | |
| Manner of Submitting the Bids: | 2 | The bidder is required to submit soft copies of their bids electronically on ECIL e-Procurement Portal, using valid Digital Signature Certificates. For necessary instructions please refer to the “User Manual for Vendor” and “User Manual of Bid Preparation” documents available in the Learning Center link on e-Procurement portal. Bids sent by post, fax, mail or e-mail will not be considered. | Agreed | |
| Method of Tender: | 3 | <u>Two Part-Bid System</u> Bidder should submit Techno-commercial & price bids separately. Only the Techno-commercial bid would be opened on the date of bid opening. Price bid will be opened, only when Techno-commercial bids are found to be qualified. Any reference to price in TECHNO-COMMERCIAL BID will render the bid invalid and such bid shall be rejected summarily. | Agreed | |
| Opening of Bids: | 4 | <u>Time and Date for Opening of Bids: (15:30 Hrs on 07.07.2025)</u> If due to any exigency, the bids are not opened on the date and time mentioned above, the bids will be opened on the next working day | Noted | |
| Validity of Bids: | 5 | The Bids should remain valid till 120 days from the date of submission of bid. | Agreed | |
| Bid Security Declaration | 6 | In place of a Bid Security, every bidder has to sign a bid security declaration form accepting that if they withdraw or modify their bids during the period of validity, or if they are awarded the contract and they fail to sign the contract, or to submit a performance security (if required) before the deadline defined in the tender document, they will be suspended for the period of one year as specified in the Bid Security Declaration Form, from being eligible to submit bids for contracts with the entity that invited the bids. Every Bidder is required to submit the Bid Security Declaration Form as per Annexure B . | Agreed | |
| Earnest Money Deposit (EMD) | 7 | Techno-Commercial Bid shall accompany interest-free EMD for Rs.1.95 Lakhs (Rupees One Lakh and Ninty Five Thousand only) in the form of Online/RTGS/NEFT/IMPS/ Demand-Draft/Bank Guarantee drawn on any scheduled bank(i.e., the Second Schedule of RBI Act, 1934) in favour of ‘Electronics Corporation of India Limited’ and payable at Hyderabad. No EMD shall be accepted in the form of Cheque. EMD is normally to remain valid for a period of 45 days beyond the final bid validity period. | Agreed | |

| | | | | |
|---|------|--|--------|--|
| EMD : Mode of payment | 8.1 | Bidder has to select the appropriate payment option to pay the EMD as applicable and enter details of the instrument. EMD may be furnished in the form of Insurance Surety Bands, Account Payee Demand Draft, Fixed Deposit Receipt from a Commercial Bank, Bank Guarantee (including e-Bank Guarantee) from a Commercial Bank or online payment in an acceptable form safeguarding the purchase's interest in all respects. | Agreed | |
| | 8.2 | Bidder should prepare the EMD as per the instructions specified in the tender document. The original instruments should reach ECIL Hyderabad latest by due date and time of bid submission. The details of the DD/any other accepted instrument, physically sent, should tally with the details available in the scanned copy and the data entered during bid submission time on above portal and in case of submission of EMD through online transfer the relevant details should be provided along with the bid to enable linking of the EMD with the tender. Otherwise the uploaded bid will be rejected. | Agreed | |
| | 8.3 | EMD, whether in the form of Demand Draft or Bank Guarantee, should be put in a separate sealed cover, super scribed as "EMD" indicating RFQ No. & Date. | Agreed | |
| | 8.4 | Techno commercial bid will not be opened if EMD is not submitted in the manner specified herein. Please furnish details of EMD submitted in Bidder's response column. The details of EMD Submitted to be furnished clearly. | Agreed | |
| | 8.5 | EMD will be refunded to the un-successful Bidder after the expiry of the final bid validity but not later than 30 days after the award of the contract and receipt of acknowledgement of P.O. issued to the bidder. EMD will be refunded to successful Bidder upon furnishing PBG (if any). As part of Techno Commercial Bid, Bidder should furnish name of the Bank, Branch, Type of Account and Account No. for refund of EMD. | Agreed | |
| | 8.6 | Offers without EMD will not be Considered and will be Summarily rejected. | Agreed | |
| | 8.7 | Bank Details of ECIL are as follows: SBI, Banjara Hills BR Hyderabad Cash Credit A/s: 10187982942 IFSC Code: SBIN0013039 | Noted | |
| Forfeiture of EMD: | 9 | If the Bidder revokes, withdraws and modifies the Bid with in the validity period of the Bid, EMD will be forfeited. In case after issue of PO, Bidder does not acknowledge PO/Supply materials and if PBG is not furnished, EMD will be forfeited. | Agreed | |
| Exemption of EMD to MSME and Start-Ups | 10.1 | MSEs registered under Udyam Registration are eligible for availing benefits under the Public Procurement Policy. | Agreed | |
| | 10.2 | The registration certificate issued from MSME/NSIC/DIC/KVIC etc. must be valid as on Bid closing date of the tender. Bidder shall ensure validity of registration certificate in case bid closing date is extended. | Agreed | |
| | 10.3 | MSEs participating in the tender must submit valid Copy of Udyam Registration Certificate to claim for the exemption | Agreed | |

| | | | | |
|--|------|--|--------|--|
| | | of EMD. | | |
| | 10.4 | The MSE Bidders to note and ensure that nature of services and goods/items manufactured mentioned in MSE's certificate matches with the nature of the services and goods /items to be supplied as per Tender. | Agreed | |
| | 10.5 | Traders/sole agent/distributors/works contract will not be considered for availing benefits under PP Policy for MSEs Order, 2012 as per Office Memorandum F.No.1(3)/2018-MA, Part-III, dated 25th March, 2022 and any amendments thereafter. | Agreed | |
| | 10.6 | Similarly, Start-Up companies with valid Certificate of Recognition as per Annexure C issued by Department of Promotion of Industrial and Internal Trade, Ministry of Commerce & Industry are eligible for availing benefit of exemption of EMD. To claim the EMD waiver, bidder needs to submit the valid Certificate of Recognition issued by DPIIT along with the techno-commercial bid. | Agreed | |
| Clarification regarding contents of the RFQ: | 11 | Bidder requiring clarification regarding the contents of the RFQ shall notify to the Buyer in writing about the clarifications sought not later than the date mentioned in the RFQ for clarifications. Clarification by the purchaser will be sent by e mail or by Speed Post | Agreed | |
| Modification and Withdrawal of Bids: | 12 | Bidder may modify or withdraw his bid after submission prior to due date and time prescribed for submission of bids. In case of modification / revision, the latest submitted bid will be treated as valid bid. Bids cannot be modified after the due date for submission of bids. No bids will be accepted after the Due Date and Time. | Agreed | |
| Clarification regarding details/contents of the Bids: | 13 | The Buyer may, at his discretion, ask the bidder for clarification of their submitted bid in writing. Change in prices or substance of the bid will not be sought, offered or permitted. The clarifications will be displayed on the website for the benefit of the bidders who are downloading the tender in case of public tender. | Agreed | |
| Pre-Bid Meeting: | 14.1 | Before submission of bids, for the bidder to understand clearly all tender requirements, a pre-bid meeting will be held on 26.06.2025 at 11:00Hrs at ECIL or through virtual meeting (WebEx Link Details will be shared through mail). | Noted | |
| | 14.2 | The bidder is required to furnish in writing queries, if any (both technical and commercial) on or before 21.06.2025 at 16:30Hrs as per the prescribed format at Annexure D . A soft copy of the queries should be sent by e-mail. | Noted | |
| | 14.3 | Buyer response to the Pre-bid queries and corrigendum, if necessary, will be uploaded on the ECIL e-Procurement Portal/ sent by email. | Noted | |
| | 14.4 | No post-bid clarification from the bidder will be entertained. | Noted | |

| | | | | |
|---------------------------|----|---|--------|--|
| Amendments to RFQ: | 15 | The buyer reserves the right to issue any amendments, corrigendum, clarification, etc. to the RFQ, giving reasonable time to the Bidder, prior to the due date and time for online bid submission. Bidders are requested to update themselves on ECIL e-Procurement portal the details such as pre-bid clarifications, corrigenda and other documents forming a part of subject RFQ, before submission of their bid | Agreed | |
| Rejection of Bids: | 16 | Canvassing by the Bidder in any form, unsolicited letter and post-tender correction may invoke summary rejection of the Bid. Any non-conformity with the techno commercial clauses and technical specifications mentioned in the RFQ will lead to Rejection of Bids | Agreed | |

Part II – ESSENTIAL DETAILS OF THE PROCUREMENT ITEMS:

This part of the RFQ Contains the Essential Details pertaining to Procurement of Items.

| Particulars | Sl. No. | Terms and Conditions | Compliance required | (Yes/No) with Deviation any |
|--|----------------|--|----------------------------|------------------------------------|
| Scope of Work: | 1 | (a) Schedule of Requirement for Fiber Optic Cables as per the details specified in following documents, (i) Scope of Supply for Fiber Optic Cables: Annexure-A.1 (ii) Technical Specifications: Annexure - A.2 | Complied | |
| Delivery Period: | 2 | Delivery of the material/ lot shall be made within 08-10 weeks from the date of receipt of LOI through e-mail / Delivery instructions from ECIL. Staggered delivery is acceptable. | Complied | |
| Mode of Delivery | 3 | The items are to be delivered strictly as per scheduled delivery date as mentioned in PO, at STORES, CNSG, ECIL HYDERABAD on FOR basis. | Complied | |
| Consignee Details: | 4 | The items are to be dispatched to In-charge Stores, MMD, Communication Systems Group, Electronics Corporation of India Limited, ECIL Post Office,Hyderabad, Telangana, India, PIN: 500062 Telephone: 040-27186575 Email: rameshakn@ecil.co.in | Noted | |
| Bid Evaluation Criteria: | 5.1 | Bid fulfilling all the eligibility and qualifying requirements of the RFQ, both technically and commercially, will be evaluated. | Complied | |
| | 5.2 | In respect of Two-Part Bid system, the techno-commercial bids submitted by the Bidders will be evaluated by the Buyer with reference to the technical characteristics of the items as mentioned in the RFQ along with terms and conditions. The compliance of techno-commercial bids would be determined on the basis of the parameters specified in the RFQ. The Price Bids of only those Bidders will be opened whose Techno-commercial Bids would clear the techno-commercial evaluation. | Complied | |
| | 5.3 | The Bidder must quote as per the Price Bid Format given in the portal, without which the Bid will be summarily rejected. | Noted | |
| | 5.4 | Order(s) will be placed on over all L1 basis. | Noted | |
| Eligibility and Pre-Qualification Criteria: | 6 | (a) Bidder should be either OEM or Dealer/Distributor/Channel Partner of the OEM. In case the Seller is not the OEM, the authorisation certificate from the OEM duly signed by authorised signatory to submit the bid, negotiate and conclude on their behalf Bids not complying this will be rejected. | Complied | |
| | | (b) The Bidder can be Proprietorship/Partnership Firm/Limited Liability Partnership/Private Limited/Limited Company /Society registered under Society's Act/Statutory Bodies etc., and should be operational from last 3 years as on 31.03.2025. Bidder should submit certificate of registration/incorporation/ partnership deed/memorandum and Articles of association/ GST registration/PAN /any other equivalent document showing date and place of incorporation as applicable. | | |
| | | (c) The bid(s) will not be entertained if the same distributor/dealer | Complied | |

| | | | |
|--|--|----------|--|
| | is representing more than one OEM for a particular item. In case of simultaneous bids, simultaneous bids from OEM directly and also through Channel Partner / Dealers / Distributors the quotes from other than OEMs will be rejected. | | |
| | (d) Bidders should have well established office set up and registration with Tax Department and shall provide required Certificate of Registration wherever applicable, viz., PAN No, GSTN etc. OEMs/ Agents should have presence in India from last three years preceding the month of March 2025. ECIL may visit the bidders office during techno commercial evaluation. | Complied | |
| | (e) The bids from the supplier / suppliers who have earlier supplied similar material to ECIL, and the PO /Contract was short closed or cancelled due to non-compliance to the technical specifications will not be considered for this tender, as the requirement is meant for a Nation important Project. | Complied | |
| | (f) The Bidder Firm/ Company should not have been blacklisted, debarred or prosecuted by any Central Government or State Government Department/ Government Organization/ PSU for corrupt, fraudulent or any other unethical business practices. Bidder shall not have any litigation pending with any of the Govt. organizations. | Complied | |
| | (g) The Bidder Firm / company should have average turnover of Rs.68 Lakh for last three audited years ending 31 st March 2024. Audited balance sheets, IT Returns and P&L account for these financial years should be furnished. OR Bidder can submit turn over certificate from Chartered Accountant. | Complied | |
| | (h) The bidder should have manufactured / supplied 10% of similar products of indented items i.e.Fiber Optic Cables in at least one of the last five years ending on 31.03.2025. | | |
| | (i) The net worth of the Bidder firm (manufacturer or principal of authorised representative) should not be negative on 31.03.2024 and also should have not eroded by more than 30 Lakhin the last three years, ending on 31.03.2024. (j) Bidder should have positive net worth as per latest audited financial results. A Certificate duly certified by a registered Chartered Accountant to be submitted. | Complied | |
| | (k) Bidder should not be insolvent, in receivership, bankrupt or being wound up, not have its affairs administered by a court or a judicial officer, not have its business activities suspended and must not be the subject of legal proceedings for any of these reasons. | Complied | |

Part III – STANDARD TERMS AND CONDITIONS

The Bidder is required to give mandatory confirmation of their acceptance of the Standard Terms and Conditions of the Tender mentioned below, which will automatically be considered as part of the contract concluded with the Bidder. Failure to do so may result in rejection of the Bid submitted by the Bidder.

| Particulars | Sl. No. | Terms and Conditions | Compliance required | (Yes/No) with Deviation if any |
|---|----------------|--|----------------------------|---------------------------------------|
| Law: | 1. | The Purchase Order (PO) shall be considered and made in accordance with the laws of India for the time being in force. The Purchase Order shall be governed by and interpreted in accordance with the laws of India. | Complied | |
| Effective Date of the Purchase Order (PO): | 2. | The PO shall come into effect on the date of issue of PO except when some other effective date is mutually agreed to and specifically indicated/provided in the PO and shall remain valid until the completion of the obligations of the parties under the contract. | Complied | |
| Acknowledgement of Purchase Order: | 3. | Order acknowledgment should be sent within 6 business days. Non receipt of PO acknowledgment with the prescribed time will be treated as acknowledgment. | Complied | |
| Amendments: | 4. | No provision of present Purchase Order shall be changed or modified in any way (including this provision) either in whole or in part except by an instrument in writing made after the date of this Purchase Order and which expressly states to amend the present Purchase Order. | Complied | |
| Termination of Purchase Order: | 5. | The Buyer shall have the right to terminate the Purchase Order in part or in full in any of the following cases: - (a) Bidder fails to supply the materials / services as per the agreed specifications. (b) The delivery of the material is delayed for causes not attributable to Force Majeure after the scheduled date of delivery with extension thereto if any. (c) The Seller is declared bankrupt or becomes insolvent. (d) As per decision of the Arbitration Tribunal. | Complied | |
| Notices: | 6. | Any notice required or permitted by the contract shall be written in the English language and may be delivered personally or may be sent by FAX or registered pre-paid mail/airmail, addressed to the last known address of the party to whom it is sent. | Complied | |
| Arbitration: | 7.1 | Any disputes or differences arising out of or in connection with the Purchase Order shall be settled by mutual amicable discussions. If this conciliation fails, unresolved disputes, if any, shall be resolved through Sole Arbitral Tribunal as per the provisions of the Arbitration & Conciliation Act, 1996 through the International Centre for Alternative Dispute Resolution | Complied | |

| | | | | |
|--|-----|--|----------|--|
| | | (ICADR), Hyderabad, under the ICADR Rules of Arbitration. | | |
| | 7.2 | The venue for Arbitration proceedings shall be at Hyderabad. | Complied | |
| | 7.3 | All disputes shall be subjected to exclusive jurisdiction of the Courts in Hyderabad (GHMC) / Medchal-Malkajiri District, notwithstanding concurrent jurisdiction of other courts of law. | Complied | |
| Penalty for use of Undue Influence: | 8. | The Bidder undertakes that he has not given, offered or promised to give, directly or indirectly, any gift, consideration, reward, commission, fees, brokerage or inducement to any person in service of the Buyer or otherwise in procuring the Contracts or forbearing to do or for having done or forborne to do any act in relation to the obtaining or execution of the present Contract or any other Contract with the Government of India for showing or forbearing to show favour or 11isfavor to any person in relation to the present Contract or any other Contract with the Government of India. Any breach of the aforesaid undertaking by the Seller or any one employed by him or acting on his behalf (whether with or without the knowledge of the Seller) or the commission of any offers by the Seller or anyone employed by him or acting on his behalf, as defined in Chapter IX of the Indian Penal Code, 1860 or the Prevention of Corruption Act, 1986 or any other Act enacted for the prevention of corruption shall entitle the Buyer to cancel the contract and all or any other contracts with the Seller and recover from the Seller the amount of any loss arising from such cancellation. A decision of the Buyer or his nominee to the effect that a breach of the undertaking had beencommitted shall be final and binding on the Seller. Giving or offering of any gift, bribe or inducement or any attempt at any such act on behalf of the Seller towards any officer/employee of the Buyer or to any other person in a position to influence any officer/employee of the Buyer for showing any favour in relation to this or any other contract, shall render the Seller to such liability/ penalty as the Buyer may deem proper, including but not limited to termination of the contract, imposition of penal damages, forfeiture of the Bank Guarantee and refund of the amounts paid by the Buyer. | Complied | |
| Non-disclosure cum Confidentiality: | 9.1 | When purchase order is awarded, the Bidder should undertake to treat purchase order and services to be rendered therein as absolutely confidential and shall not disclose or provide any information, which may come to your knowledge or passed on to you during the execution by ECIL or end customer, to any third party, person or country under any circumstances without prior written consent of ECIL. | Complied | |
| | 9.2 | The Bidder should keep all technical specifications, | Complied | |

| | | | | |
|----------------------------------|------|---|----------|--|
| | | scope, details of equipment at and corresponding locations, terms and conditions, including, Drawings, Site Plans as confidential and shall not disclose to any third party, without prior written consent of ECIL. | | |
| | 9.3 | ECIL reserves the right to initiate legal action as per prevailing law against the Bidder and / or claim damages for non-compliance. | Complied | |
| Transfer and Sub-letting: | 10 | The Seller has no right to give, bargain, sell, assign or sublet or otherwise dispose of the Contract or any part thereof, as well as to give or to let a third party take benefit or advantage of the present Contract or any part thereof. | Complied | |
| Tolerance Clause | 11 | To take care of any change in the requirement during the period starting from issue of RFQ till placement of the contract, Buyer reserves the right to 15% plus/minus increase or decrease the quantity of the required goods up to that limit without any change in the terms & conditions and prices quoted by the Seller. While awarding the contract, the quantity ordered can be increased or decreased by the Buyer within this tolerance limit. | Complied | |
| Taxes and Duties | 12.1 | Bidders must indicate separately the relevant Taxes/Duties likely to be paid in connection with delivery of completed goods specified in RFQ. In absence of this, the total cost quoted by them in their bids will be taken into account in the ranking of bids. | Complied | |
| | 12.2 | If a bidder is exempted from payment of any duty/tax up to any value of supplies from them he should clearly state that no such duty/tax will be charged by them up to the limit of exemption which they may have. If any concession is available in regard to rate/quantum of any Duty/tax, it should be brought out clearly. In such cases, relevant certificate will be issued by the Buyer later to enable the Seller to obtain exemptions from taxation authorities. | Complied | |
| | 12.3 | Any changes in levies, taxes and duties levied by Central / State governments such as CGST, SGST & IGST etc. on final product upward as a result of any statutory variation taking place within contract period shall be allowed reimbursement by the Buyer, to the extent of actual quantum of such duty/tax paid by the Seller. Similarly, in case of downward revision in any such duty/tax, the actual quantum of reduction of such duty/tax shall be reimbursed to the Buyer by the Seller. All such adjustments shall include all reliefs, exemptions, rebates, concession etc. if any, obtained by the Seller. | Complied | |
| | 12.4 | In case of extension of Delivery Period any increase in taxes, duties, levies etc. will not be paid to the seller unless the reasons for the delay are attributable to Buyer. In case of decrease the difference to be passed on to the buyer. | Complied | |

| | | | | |
|--------------------------|------|---|----------|--|
| GST: | 13.1 | Bidders should quote GST separately in their quote. In the absence of any such stipulation in the bid, it will be presumed that the prices quoted by the Bidders are inclusive of GST and no liability of GST will devolve upon the Buyer. | Complied | |
| | 13.2 | On the Bids quoting GST extra, the rate, the type of GST – Centre, State, Integrated, Union Territory applicable at the time of supply should be shown separately. GST will be paid to the Seller at the rates mentioned in schedule of GST rates, based on the HSN code and as notified by the GST council. | Complied | |
| Paying Authority: | 14 | <p>The payment of bills will be made by Sr DGM, Bills, ECIL. All payments will be released from ECIL, Hyderabad through e-payment by ECS/EFT mechanism.</p> <p>The following documents are to be submitted by the seller with the items for making the payment:</p> <p>(a) Ink-signed copy of AWB / Bill of Lading (in case of imports)</p> <p>(b) Ink-signed copy of Commercial invoice / Seller's bill.</p> <p>(c) Inspection note/ Duly signed test reports by Authorized agency for clearance of the goods</p> <p>(d) E-way Bill</p> <p>(e) Copy of Purchase Order</p> <p>(f) Packing list</p> <p>(g) Certificate of Conformity (COC) and Country of origin</p> <p>(h) Guarantee / Warranty certificate.</p> <p>(i) Performance Bank guarantee where applicable.</p> <p>(j) Order Amendments (if any)</p> <p>(k) Details for electronic payment viz. Account holder's name, Bank name, Branch name and address, Account type, Account number, IFSC code, MICR code, (in case of imports SWIFT Code and BIC number also).</p> <p>(l) Any other document / certificate that may be required as per the Purchase Order / Contract.</p> | Complied | |
| Fall clause | 15.1 | <p>The following Fall Clause will form part of the contract placed on successful Bidder:-</p> <p>(a) The price charged for the goods supplied under the contract by the Seller shall in no event exceed the lowest prices at which the Seller sells the goods or offer to sell goods of identical description to any persons/Organization including the purchaser or any department of the Central Government or any Department of the State Government or any statutory undertaking of the Central or State Government as the case may be during the period or till the performance of all Supply Orders placed during the currency of the</p> | Complied | |

| | | | | |
|-----------------------------|------|--|----------|--|
| | | contract is completed. | | |
| | 15.2 | <p>(b) If at any time, during the said period the Seller reduces the sale price, sells or offer to sell such goods to any person/organization including the Buyer or any Department of Central Government or any Department of the State Government or any Statutory undertaking of the Central or State Government as the case may be at a price lower than the price chargeable under the contract, the Seller shall forthwith notify such reduction or sale or offer of sale to ECIL and the price payable under the contract for the goods of such reduction of sale or offer of the sale shall stand correspondingly reduced. The above stipulation will, however, not apply to:-</p> <p>(i) Exports by the Seller.</p> <p>(ii) Sale of goods as original equipment at a price lower than the prices charged for normal replacement.</p> <p>(iii) Sale of goods such as drugs which have expiry dates.</p> <p>(iv) Sale of goods at lower price on or after the date of completion of sale/placement of the order of goods by the authority concerned under the existing or previous Contracts as also under any previous contracts entered into with the Central or State Government Departments, including their undertakings excluding joint sector companies and/or private parties and bodies.</p> | Complied | |
| Risk Purchase clause | 16.1 | Should the goods or any part thereof not be delivered within the time or times specified in the contract documents, or if defective delivery is made in respect of the goods or any part thereof, the Buyer shall after granting the Seller 60 days to cure the breach, be at liberty, without prejudice to the right to recover liquidated damages as a remedy for breach of contract, to declare the contract as cancelled either wholly or to the extent of such default | Complied | |
| | 16.2 | Should the goods or any part thereof not perform in accordance with the specifications / parameters provided by the SELLER during the check proof tests to be done in the BUYER's country, the BUYER shall be at liberty, without prejudice to any other remedies for breach of contract, to cancel the contract wholly or to the extent of such default. | Complied | |
| | 16.3 | <p>In case of a material breach that was not remedied within 60 days, the BUYER shall, having given the right of first refusal to the SELLER be at liberty to purchase, manufacture, or procure from any other source as he thinks fit, other goods of the same or similar description to make good:-</p> <p>(a) Such default</p> | Complied | |

| | | | | |
|------------------------------|-------------------|---|---|----------|
| | | (b) In the event of the contract being wholly determined the balance of the goods remaining to be delivered there under. | | |
| | 16.4 | Any excess of the purchase price, cost of manufacturer, or value of any goods procured from any other supplier as the case may be, over the contract price appropriate to such default or balance shall be recoverable from the SELLER. | Complied | |
| Force Majeure clause: | 17.1 | Neither party shall bear responsibility for the complete or partial non-performance of any of its obligations (except for failure to pay any sum which has become due on account of receipt of goods under the provisions of the present contract), if the non-performance results from such Force Majeure circumstances as Flood, Fire, Earth Quake and other acts of God as well as War, Military operation, blockade, Acts or Actions of State Authorities, Epidemic, Pandemic, Government Guidelines or any other circumstances beyond the parties control that have arisen after the conclusion of the present contract. | Complied | |
| | 17.2 | In such circumstances the time stipulated for the performance of an obligation under the present contract is extended correspondingly for the period of time of action of these circumstances and their consequences. | Complied | |
| | 17.3 | The party for which it becomes impossible to meet obligations under this contract due to Force Majeure conditions, is to notify in written form the other party of the beginning and cessation of the above circumstances immediately, but in any case, not later than 10 (Ten) days from the moment of their beginning. | Complied | |
| | 17.4 | If the impossibility of complete or partial performance of an obligation lasts for more than 6 (six) months, either party hereto reserves the right to terminate the contract totally or partially upon giving prior written notice of 30 (thirty) days to the other party of the intention to terminate without any liability other than reimbursement on the terms provided in the agreement for the goods received. | Complied | |
| | 17.5 | Certificate of a Chamber of Commerce (Commerce and Industry) or other Competent Authority or organization of the respective country shall be a sufficient proof of commencement and cessation of the above circumstances. | Complied | |
| | Insurance: | 18 | For purchase orders placed on FOR, ECIL basis the necessary insurance to ensure safe transit of material should be catered for by the supplier. Where the terms of delivery are either ex-works or ex-warehouse or FOB/CIF/CIP, the dispatch particulars are to be intimated to ECIL to enable transit with the requisite insurance. The supplier will be responsible for | Complied |

| | | | | |
|--|----|---|----------|--|
| | | shortage/damage during transit and as such the consignment may be insured by the supplier at his option and cost. | | |
| Quality: | 19 | The quality of the goods delivered according to the Contract shall correspond to the technical conditions and standards valid for the deliveries of the same goods for in Seller's country or specifications enumerated as per RFQ and shall also include therein modification to the goods suggested by the Buyer. Such modifications will be mutually agreed to as per amendments to the contract. The Seller confirms that the goods to be supplied under this Contract shall be newly manufactured. | Complied | |
| Conditional Offer: | 20 | No conditional offer will be accepted which is not in conformity with the specifications and terms & conditions mentioned in the RFQ. | Complied | |
| Patents and Other Industrial Property Rights: | 21 | The prices quoted by the bidders shall be deemed to include all amounts payable for the use of patents, copyrights, registered charges, trademarks and payments for any other industrial property rights. The Seller shall indemnify the Buyer against all claims from a third party at any time on account of the infringement of any or all the rights, whether such claims arise in respect of manufacture or use. The Seller shall be responsible for the completion of the supplies including spares, tools, technical literature and training aggregates irrespective of the fact of infringement of the supplies, irrespective of the fact of infringement of any or all the rights mentioned above. | Complied | |
| Conflict of Interest: | 22 | Any bidder having a conflict of interest, which substantially affects fair competition, shall not be eligible to bid in this tender. Bids found to have a conflict of interest shall be rejected as non-responsive. Bidder shall be required to declare the absence of such conflict of interest in Annexure E 'Eligibility Declarations'. A bidder in this Tender Process shall be considered to have a conflict of interest if the bidder: - (a) directly or indirectly controls, is controlled by or is under common control with another Bidder; or (b) receives or have received any direct or indirect subsidy/ financial stake from another bidder; or (c) has the same legal representative/ agent as another bidder for purposes of this bid. A Principal can authorize only one agent, and an agent also should not represent or quote on behalf of more than one Principal. However, this shall not debar more than one Authorised distributor from quoting equipment manufactured by an Original Equipment Manufacturer (OEM), in procurements under Proprietary Article Certificate; or (d) has a relationship with another bidder, directly or through common third parties, that puts it in a position to have access to information about or influence the | Complied | |

| | | | | |
|--|----|--|----------|--|
| | | <p>bid of another Bidder or influence the decisions of the Procuring Entity regarding this Tender process; or</p> <p>(e) participates in more than one bid in this tender process. Participation in any capacity by a Bidder (including the participation of a Bidder as sub-contractor in another bid or vice-versa) in more than one bid shall result in the disqualification of all bids in which he is a party. However, this does not limit the participation of a non-bidder firm as a sub-contractor in more than one bid; or</p> <p>(f) would be providing goods, works, or non-consulting services resulting from or directly related to consulting services that it provided (or were provided by any affiliate that directly or indirectly controls, is controlled by, or is under common control with that firm), for the procurement planning (inter-alia preparation of feasibility/ cost estimates/ Detailed Project Report (DPR), design/ technical specifications, terms of reference (ToR)/ Activity Schedule/ schedule of requirements or the Tender Document etc) of this Tender process; or</p> <p>(g) has a close business or family relationship with a staff of the Procuring Organisation who: (i) are directly or indirectly involved in the preparation of the Tender document or specifications of the Tender Process, and/or the evaluation of bids; or (ii) would be involved in the implementation or supervision of resulting Contract unless the conflict stemming from such relationship has been resolved in a manner acceptable to the Procuring Entity throughout the Tender process and execution of the Contract.</p> | | |
| Consideration of Abnormally Low Bids: | 23 | <p>An Abnormally Low bid is one in which the bid price, in combination with other elements of the bid, appears so low that it raises substantive concerns as to the Bidder's capability to perform the contract at the offered price. ECIL shall in such cases seek written clarifications from the Bidder, including detailed price analyses of its bid price concerning scope, schedule, allocation of risks and responsibilities, and any other requirements of the Tender Document. If, after evaluating the price analyses, ECIL determines that Bidder has substantively failed to demonstrate its capability to deliver the contract at the offered price, the ECIL shall reject the bid/ proposal, and evaluation shall proceed with the next ranked bidder.</p> | Complied | |

Part IV – SPECIAL TERMS & CONDITIONS

The Bidder is required to give confirmation of their acceptance of the Special Terms and Conditions of the Tender mentioned below, which will automatically be considered as part of the contract concluded with the Bidder.

| Particulars | Sl. No. | Terms and Conditions | Compliance required | (Yes/No) with Deviation if any |
|---|----------------|--|----------------------------|---------------------------------------|
| OEM Authorization Certificate: | 1 | Bids should be accompanied by Authorization Certificate from the OEM duly signed by Authorised Signatory of OEM. Indian Dealers of foreign OEMs shall have required Import Export Registration with concerned authorities. Indian agents/Dealers of foreign OEMs shall have experience of selling the imported items/software and shall be conversant with preparation of required documents and agreements etc.. | Complied | |
| Certificate of Confirmity (CoC): | 2 | OEM COC to be provided along with each batch of supply without which item will not be accepted. OEM COC should include information of the materials being supplied along with batch code or date code or any traceability towards supplied materials. Material will be summarily rejected in the absence of the OEM COC. | Complied | |
| Year of Production | 3 | The Supplies should be of the latest manufacture (same year as the year of Placement of Purchase Order or later). | Complied | |
| Terms of Price: | 4 | The prices shall be quoted by the indigenous bidders strictly on FOR, ECIL, Hyderabad basis and should include all charges towards packing, forwarding, freight, transit insurance and unloading etc. | Complied | |
| Payment Terms: | 5 | (a) 100% of payment will be made within 60 days from the date of receipt against acceptance of material at ECIL Stores, on submission of all required documents, such as Tax Invoice, Delivery Challans. Payment will be done on pro-rata basis in case material is received in partial shipments. (b) Payment of taxes will be made to the Seller after submission of tax remittance documents and uploading the tax return by the vendor, in turn invoice has to appear in GSTR2A of ECIL. (c) In case of MSE vendor 100% payable within 45days after receipt and acceptance of goods at ECIL stores on submission of all required documents such as Tax Invoice, Delivery Challans. | Complied | |
| | | (d) In order to address the financial needs of MSE firms, Gol has introduced a platform facilitating the financing of their trade receivables, through multiple | Complied | |

| | | | | |
|---|-----|--|----------|--|
| | | <p>financiers which is termed as Trade Receivable Discounting System(TReDS). At TReDS, auctioning of invoices at competitive and transparent environment is done by financiers based on Buyers credit profile.</p> <p>(e) ECIL is registered on TReDS platform with “A-TReDSLtd.(Invoicemart)”. Desirous MSE Bidders/Vendors, who want to receive payments through TReDS platform, have to submit the invoice to ECIL along with the necessary requirements as per PO and the payment terms. Upon receipt and acceptance of the supplied materials/completion of services and receipt of invoices with mandated enclosures and after due certification of invoices with enclosures by commercial/material dept., Finance dept. shall upload the invoices on the Invoicemart, TReDS platform and process the invoices for payment. Post uploading on the platform, the financier would be bidding for the invoices and respective MSE vendors would be accepting the bid, so that they can get the disbursement from the Financier.</p> <p>(f)MSE bidders desirous to receive payment through TReDS platform may avail the facility if they are already registered on “Invoicemart” TReDS platform or by registering on it.</p> | | |
| | | (g) The bids not comply with above payment terms shall be rejected summarily. | Complied | |
| Warranty: | 6 | Any materials supplied should be free from any defects arising from faulty material, design or workmanship and should be guaranteed for quality / satisfactory performance for a period of 12 months from the date of supply. During this warranty period, if any defects develop arising from faulty material, design or workmanship; the supplier shall remedy such defects at his own cost. If it becomes necessary, the supplier should replace any defective portion of the goods or replace thematerials as a whole. | Complied | |
| Product Support: | 7 | The Seller hereby agrees for Product support for maximum of 20 years including warranty after the date of acceptance of stores. | Complied | |
| Performance cum Warranty Guarantee (PCWG): | 8.1 | Within 15 days of award of Letter of Intent (LOI), Successful Bidder should submit Performance cum Warranty Guarantee for 3% of Purchase Order value in the form of Insurance Surety Bonds, Account Payee Demand Draft, Fixed Deposit Receipt from a Commercial bank, Bank Gurantee from a Commercial bank or online payment. | Complied | |
| | 8.2 | In case, same is submitted through Bank Guarantee, the same shall be strictly as per format in Annexure F on a Scheduled Bank (except Co-Operative Banks), valid upto Delivery Period + warranty period | Complied | |

| | | | | |
|--|-----|--|----------|--|
| | | + 2 months from the date of issue of Bank Guarantee to cover the Bidder's obligations on performance on the PO and warranty has to be furnished. | | |
| | 8.3 | Purchase Order will be released within 6 working days after receipt of PCWG. The delivery schedule will be considered from the date of Letter of Intent (LOI). | Complied | |
| | 8.4 | If the Guarantee is furnished by way of Bank Guarantee, the same should be extended from time to time to serve the intended obligation of successful Bidder, failing which ECIL reserves the right to invoke the Bank Guarantee. If the successful Bidder fails to furnish the PCWG, ECIL reserves the right to cancel PO and invoke Risk Purchase and levy maximum LD; without any further notice. | Complied | |
| Liquidated Damages: | 9 | In the event of the Seller's failure to supply the goods as specified in this Purchase Order, the Buyer may, at his discretion, withhold any payment until the completion of the contract. The BUYER may also deduct from the SELLER as agreed, liquidated damages to the sum of 0.5% of the contract price of the delayed/undelivered stores/services mentioned above for every week of delay or part thereof, subject to the maximum value of the Liquidated Damages being not higher than 10% of the value of delayed/undelivered goods/stores. | Complied | |
| Inspection Instructions: | 10 | The Inspection of items/equipment will be carried out by the inspection agency of ECIL/User at ECIL premises or vendor site or at customer recommended place, as the case may be. In the event of shortage / damage noticed upon receipt and opening of packages at ECIL Stores, all such shortages or damages shall be made good by the bidder within 10 days from the date of reporting, free of all charges. | Complied | |
| Documents, COCs & TDRs | 11 | Certificate of Conformance, Datasheet or drawings and Test Report shall be submitted along with the items. | Complied | |
| Terrain and Climatic Conditions | 12 | All weather capability in mountainous terrain which includes sub-zero temperature, snow, fog, wind speed, heavy rain, etc. The operational temperature range is -20°C to +45°C (including COTS). The storage temperature range is -30°C to +70°C for Sheltered supply items. The operational maximum altitude will be 4160m. | Complied | |
| Franking Clause: | 13 | The following franking clause will form of the part of the Purchase Order placed on Successful Bidders: (a) In case of Acceptance of Store(s): The fact that the goods have been inspected after the delivery period and passed by the Inspecting Officer will not have the effect of keeping the contract alive. The goods are being passed without prejudice to the | Complied | |

| | | | | |
|---|------|--|----------|--|
| | | rights of the buyer under the terms and conditions of the Contract. (b) In Case of Rejection of Store(s): The fact that the goods have been inspected after the delivery period and rejected by the Inspecting Office will not bind the Buyer in any manner. The goods are being rejected without prejudice to the right of the Buyer under the terms and conditions of the Contract. | | |
| Repeat Order Clause: | 14 | The Purchase Order will have a Repeat Order Clause, wherein the Buyer can order upto 100% quantity of the items under the present contract within one year from the date of supply/successful completion of this Purchase Order, the cost, terms & conditions remaining the same. The Bidder is to confirm acceptance of this clause. It will be entirely the discretion of the Buyer to place the Repeat order or not. | Complied | |
| Packing and Marking Instructions: | 15.1 | The Seller shall provide packing and preservation of the equipment and spares/goods contracted so as to ensure their safety against damage in the conditions of transportation, transshipment, storage and weather hazards during transportation, subject to proper cargo handling. The Seller shall ensure that the stores are packed in containers, which are made sufficiently strong. The packing cases should have hooks for lifting by crane/fork lift truck. Tags with proper marking shall be fastened to the special equipment, which cannot be packed. | Complied | |
| | 15.2 | A label in English shall be either pasted on the carton or painted indicating the under mentioned details of the item contained in the carton. The cartons shall then be packed in packing cases as required. Packing List: a) Buyer Details: b) Seller Details: c) Consignee Details: d) Purchase Order No: e) Package No.: f) Part Number: g) Nomenclature: h) Quantity contracted: | Complied | |
| | 15.3 | If necessary, each package shall be marked with warning inscriptions: TOP>, "Do not turn over", category of cargo, etc. | Complied | |
| | 15.4 | One copy of the packing list in English shall be inserted in each cargo package. | Complied | |
| Purchase Preference for MSE Vendors: | 16 | Purchase preference will be given to MSEs as defined in Public Procurement Policy for Micro and Small Enterprises (MSEs) Order, 2012 dated 23.03.2012 issued by Ministry of Micro, Small and Medium Enterprises and its subsequent Orders/Notifications issued by concerned Ministry. If the bidder wants to avail the Purchase preference, the bidder must be the manufacturer of the offered | Complied | |

| | | | | |
|--|----|---|----------|--|
| | | <p>product in case of bid for supply of goods. Traders are excluded from the purview of Public Procurement Policy for Micro and Small Enterprises. In respect of bid for Services, the bidder must be the Service provider of the offered Service. Relevant documentary evidence in this regard shall be uploaded along with the bid in respect of the offered product or service.</p> <p>(b) If L-1 is not an MSE and MSE Supplier(s) has/have quoted price within L-1+ 15% (where MSE Purchase Preference is applicable) of margin of purchase preference /price band defined in relevant policy, such Supplier shall be given opportunity to match L-1 price and contract will be awarded for 100% percentage of total quantity (if MSE Purchase Preference is applicable).</p> <p>(c) It is advised to refer the OM No.F.1/4/2021-PPD dated 18.05.2023 for compliance of Concurrent application of Public Procurement Policy for Micro and Small Enterprises Order, 2012 and Public Procurement (Preference to Make in India) Order, 2017.</p> <p>(d) The MSE Vendor has to submit the Copy of Udyam Registration Certificate along with relevant supporting documents.</p> | | |
| Relaxation for Start-Ups | 17 | <p>(a) Prequalification Criteria with respect to Prior Turnover and Prior Experience may be relaxed for Start-ups (whether MSEs or otherwise) as per the Government of India guidelines.</p> <p>(b) The bidder who intends to participate as “Start-up” company should enclose the Certificate of Recognition issued by Department of Industrial Policy and Promotion, Ministry of Commerce & Industry, Govt. of India during submission of Technical bid.</p> <p>(c) The following declaration should be given by Start-ups at the time of tender submission: “We are a ‘Start-up’ company and we are enclosing copy of certificate of recognition issued by Department of Industrial Policy and Promotion, Ministry of Commerce & Industry, Govt. of India.”</p> | Agreed | |
| Restrictions under Rule 144(xi) of GFR 2017 | 18 | <p>The Provisions contained in Order (Public Procurement No.1) of DOE, Public Procurement Division, No. F.No.6/18/2019-PPD, dt. 23.7.2020 and as amended / clarified from time to time, shall be applicable to this tender. Details are at Annexure G. A certificate for the same as per the format mentioned at Annexure Fis to be submitted by the bidder.</p> | Complied | |
| Purchase Preference to Make in India | 19 | <p>Procurement under this bid is reserved for purchase from Class I local supplier as defined in public procurement (Preference to Make in India), Order 2017 as amended from time to time and its subsequent Orders/Notifications issued by concerned Nodal Ministry for specific</p> | Complied | |

| | | | | |
|------------------------------|----|--|----------|--|
| | | <p>Goods/Products. However, eligible micro and small enterprises will be allowed to participate. The minimum local content to qualify as a class I local supplier is denoted in the bid document. All bidders must upload a certificate from the OEM regarding the percentage of the local content and supplier is denoted in the bid document. All bidders must upload a certificate from the OEM regarding the percentage of the local content and the details of locations at which the local value addition is made along with their bid, failing which the bid is liable to be rejected. In case their quoted value is more than Rs.10 Crore, the declaration relating to percentage of local content shall be certified by the statutory auditor or cost auditor, if the OEM is a company and by a practicing cost accountant or a chartered accountant for OEMs other than companies as per the Public Procurement (preference to Make-in - India) order 2017 dated 04.06.2020. In case Buyer has selected Purchase preference to Micro and Small Enterprises clause in the bid, the same will get precedence over this clause.</p> <p>Local Content declaration & Certification formats are placed at Annexure H.</p> | | |
| Minimum Local Content | 20 | Minimum Local Content required for Class I Local Suppliers is 50% | Complied | |

Part V – PRICE BID FORMAT

5.1. The Price Bid Format is given below and Bidders are required to fill this correctly with full details.

| <u>S No.</u> | <u>Description</u> | <u>Curr</u> | <u>Qty</u> | <u>Unit Material Cost</u> | <u>Total Material Cost</u> | <u>Unit Material Cost with taxes</u> | <u>Total Material Cost with taxes</u> |
|--------------|---|-------------|------------|---------------------------|----------------------------|--------------------------------------|---------------------------------------|
| 1. | Fiber Optic Cable Single Mode with ODC-4 Plug connector to ODC-4 Plug Connector on both ends with dust caps, Single Mode Optic fibre suitable for D-Link Optic Ethernet Transceiver DEM-432XT, D-Link Ethernet Switch DGS-3130-30PS, with metal drum and handle, 1000mtrs length +Tol 5% Operating Temperature: -30°C to +85°C | INR | 50 Nos | | | | |
| 2. | Fiber Optic Cable Single Modewith ODC-4 Socket Flange Connector one end (mating to item S.No.1) and4 LC Simplex on another end, Single Mode Optic fibre suitable for D-Link Optic Ethernet Transceiver DEM-432XT, D-Link Ethernet Switch DGS-3130-30PS7mtrs length Operating Temperature: -30°C to +85°C | INR | 116 Nos | | | | |
| 3. | Fiber Optic LC-LC Single Mode, Duplex Patch Cord, Ceramic, Standard Fibre 9/125, Suitable for D-Link Optic Ethernet Transceiver DEM-432XT, D-Link Ethernet Switch DGS-3130-30PS, 3mtrs length Operating Temperature: -30°C to +85°C | INR | 58 nos | | | | |

Notes:

| Particulars | S No. | Terms and Conditions | Compliance required | (Yes/No) with Deviation if any |
|--------------------|--------------|---|----------------------------|---------------------------------------|
| | 1 | If there is any discrepancy between the unit price and the total price the unit price will prevail. If there is a discrepancy between words and figures, the amount in words will prevail for calculation of price. | Noted | |
| | 2 | The Lowest Acceptable Bid will be considered further for placement of Purchase Order after complete clarification and price negotiations, if any, as decided by the Buyer. | Noted | |
| | 3 | Price Bid: The price bid format is as per the format given in the financial offer of the ECIL e-Procurement portal. | Noted | |
| | 4 | The basic prices should be offered on INR against each line entry, inclusive of packing forwarding, freight, insurance, unloading & including all other incidental as per our on-line portal. | Agreed | |
| | 5 | The quoted price will only be considered till 2 decimal places | Agreed | |

Scope of Supply for Fiber Optic Cables

| S No. | Description of Items | Quantity | Denomination Unit of Measurement (UOM) | Complied/ Not complied |
|-------|---|----------|---|---------------------------|
| 1. | Fiber Optic Cable Single Mode with ODC-4 Plug connector to ODC-4 Plug Connector on both ends with dust caps, Single Mode Optic fibre suitable for D-Link Optic Ethernet Transceiver DEM-432XT, D-Link Ethernet Switch DGS-3130-30PS, with metal drum and handle, 1000mtrs length +Tol 5% Operating Temperature: -30°C to +85°C | 50 | Nos | |
| 2. | Fiber Optic Cable Single Modewith ODC-4 Socket Flange Connector one end (mating to item S.No.1) and 4 LC Simplex on another end, Single Mode Optic fibre suitable for D-Link Optic Ethernet Transceiver DEM-432XT, D-Link Ethernet Switch DGS-3130-30PS 7mtrs length Operating Temperature: -30°C to +85°C | 116 | Nos | |
| 3. | Fiber Optic LC-LC Single Mode, Duplex Patch Cord, Ceramic, Standard Fibre 9/125, Suitable for D-Link Optic Ethernet Transceiver DEM-432XT, D-Link Ethernet Switch DGS-3130-30PS, 3mtrs length Operating Temperature: -30°C to +85°C | 58 | Nos | |
| | Note: Test Reports, Datasheets/Drawings, CoC to be provided along with materials | | | |

Technical Specification of Fiber Optic Cables

Technical Specifications for Fiber Optic Cables for Item S.Nos. 1 to 3.

1. Fiber Optic Cable Single Mode: 1000m+Tol 5%, drum with handle

| S.No. | Description | Length | Qty |
|-------|---|-------------------|---------|
| 1 | Fiber Optic Cable Single Mode with ODC-4 Plug connector to ODC-4 Plug Connector on both ends with dust caps, Single Mode Optic fibre suitable for D-Link Optic Ethernet Transceiver DEM-432XT, D-Link Ethernet Switch DGS-3130-30PS, with metal drum and handle, 1000mtrs length +Tol 5% Operating Temperature: -30°C to +85°C | 1000m + Tol 5% | 50 Nos. |

2. Fiber Optic Cable (Flange Connector one end and 4XLC Simplexon another end)

| S.No. | Description | Length | Qty |
|-------|---|--------|---------|
| 1 | Fiber Optic Cable Single Mode with ODC-4 Socket Flange Connector one end (mating to item S.No.1) and 4 LC Simplexon on another end, Single Mode Optic fibre suitable for D-Link Optic Ethernet Transceiver DEM-432XT, D-Link Ethernet Switch DGS-3130-30PS 7mtrs length Operating Temperature: -30°C to +85°C | 7m | 116 Nos |

3. Fiber Optic LC – LC Single Mode Duplex Patch Cord

| S.No. | Description | Length | Qty |
|-------|--|--------|--------|
| 1 | Fiber Optic LC-LC Single Mode, Duplex Patch Cord, Ceramic, Standard Fibre 9/125, Suitable for D-Link Optic Ethernet Transceiver DEM-432XT, D-Link Ethernet Switch DGS-3130-30PS, 3mtrs length Operating Temperature: -30°C to +85°C | 3m | 58 Nos |

Figure:1 Fiber Optic Cable Single Mode: 1000m+Tol 5%, drum with handle

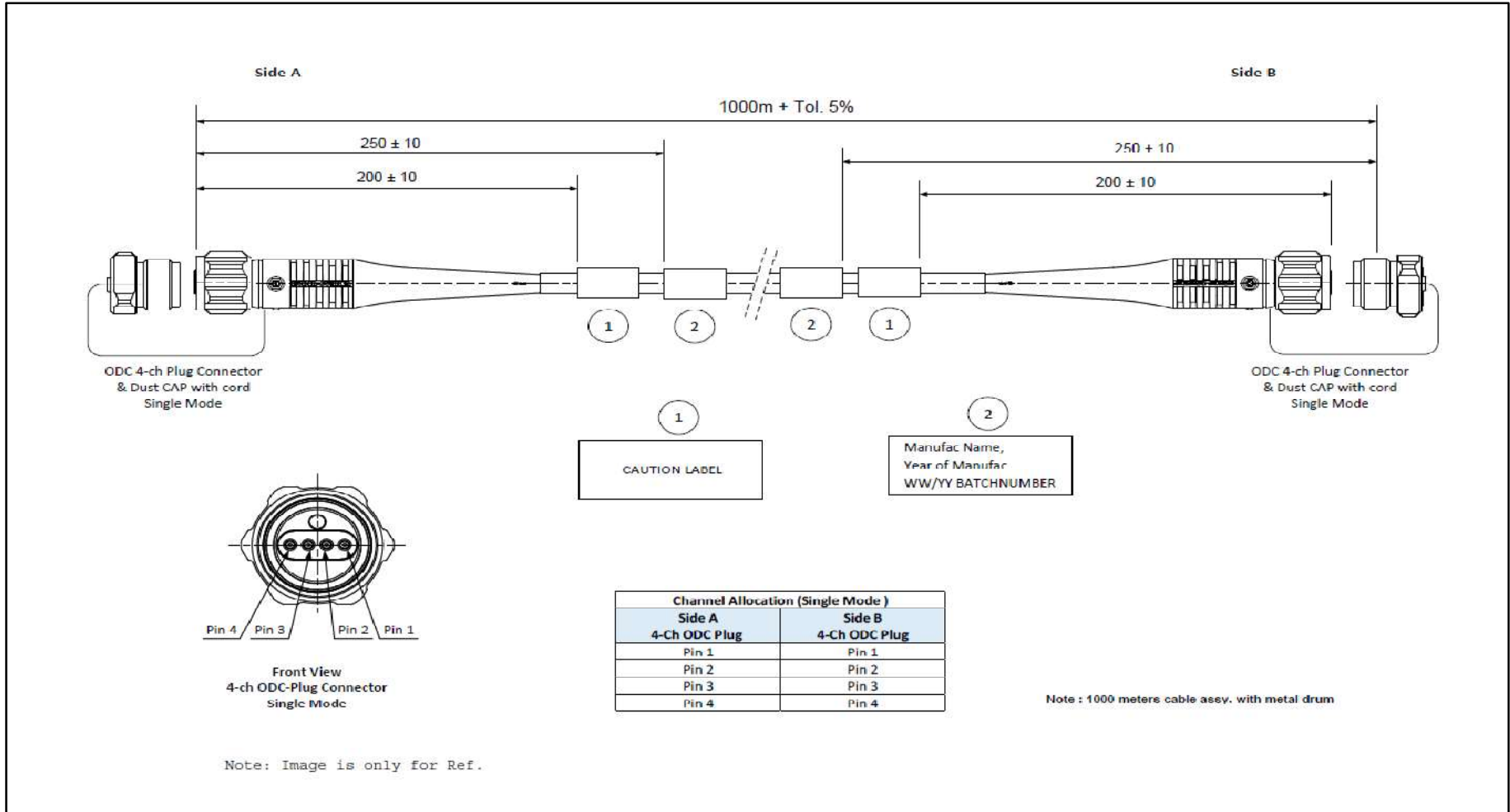

Figure:2 Fiber Optic Cable (Flange Connector one end and 4XLC Simplexon another end)

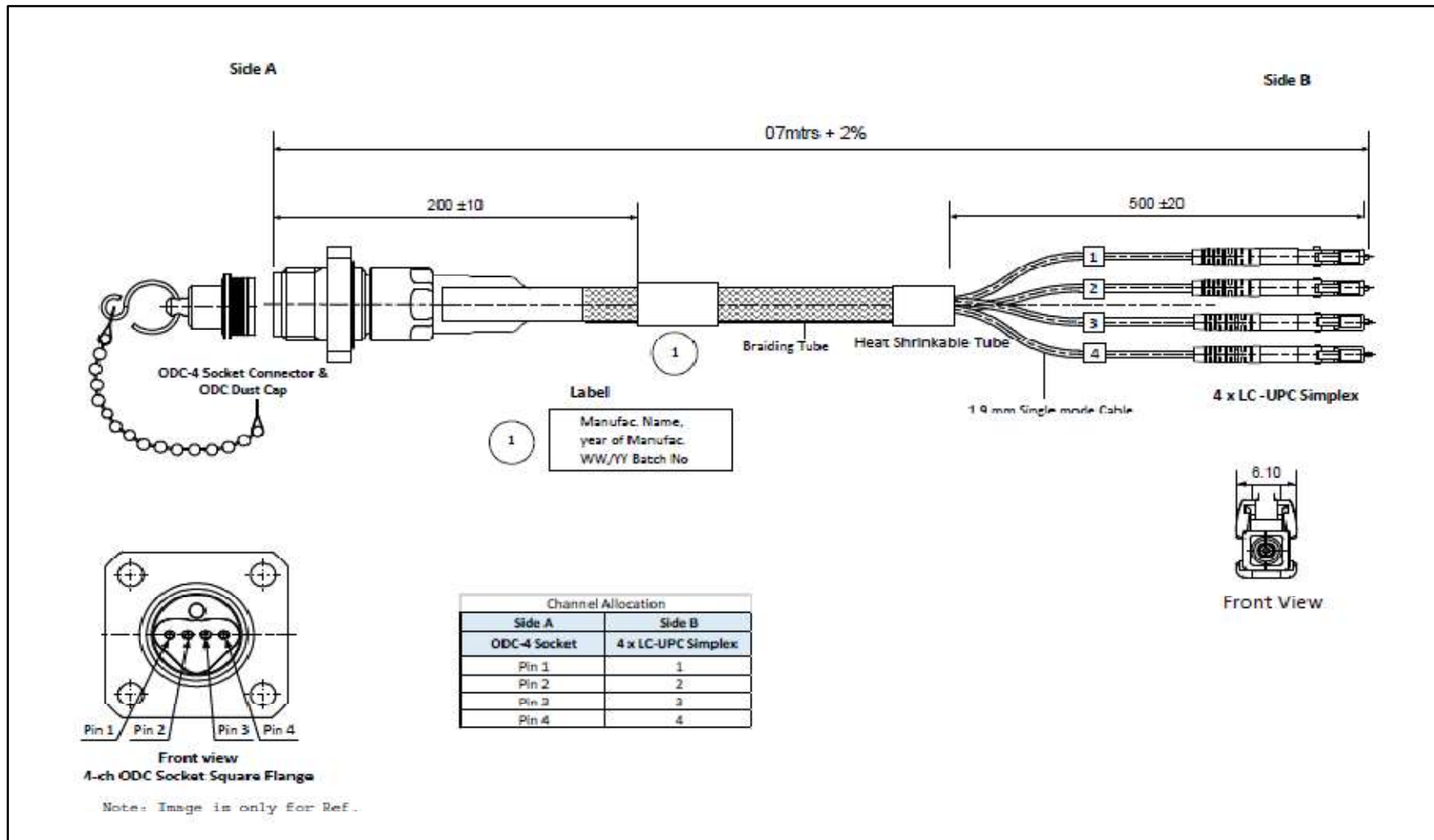
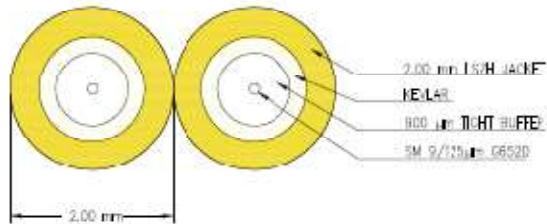
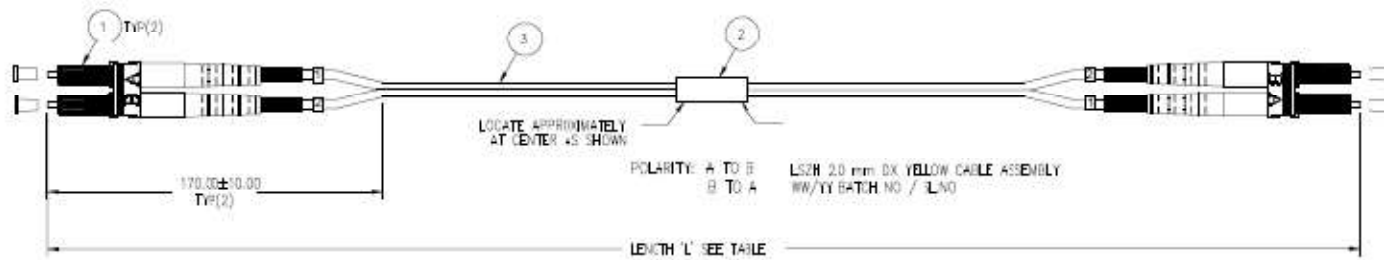

Figure:3 Fiber Optic LC – LC Single Mode Duplex Patch Cord

NOTES:

- 1 L: 310mm/1250mm ± 0.0049
- AL: 310mm/1250mm ± 0.008 UPC
- Working Temperature: -30degC to +85degC
- Connector Ferrule: Ceramic



Note: Image is only for ref.

| ITEM | DESCRIPTION | QTY | UNIT |
|------|-----------------------------|-----------|------|
| 3 | LSZH 2.0 mm DX YELLOW CABLE | SEE TABLE | M |
| 2 | PRODUCT LABEL | 1 | PCS |
| 1 | LC 2.0 mm DX BLUE CONN | 2 | PCS |

(ON THE LETTER HEAD OF THE COMPANY)
Bid Security Declaration Form

Date: _____

Tender No. _____

To
ECIL,
ECIL (Post), Hyderabad

In accordance with Government of India, Ministry of Finance OM No. F.9/4/2020-PPD dated 12.11.2020

1. I/We accept that I/We will, automatically be suspended from being eligible for participating in bidding for any contract with you for the period of 1 (One) year, in case of, and starting from the date of, breaching our obligation(s) under the bidding conditions due to:
 - a) Withdrawing our bid, or any part of our bid, during the period of bid validity against the Tender No. _____ or any extension of the period of bid validity which we subsequently agreed to;
or
 - b) Having been notified of the acceptance of our bid by you during the period of bid validity,
 - (i) Failing or refusing to execute the Contract, or
 - (ii) Failing or refusing to furnish the performance security, if required, in accordance with the Instructions to Bidders.
2. I/We understand this Bid Security Declaration shall expire if we are not the successful Bidder.

Signed:

[signature of person whose name and capacity are shown below]

Name: [name of person signing the Bid Security Declaration], in the capacity of [legal capacity of person signing the Bid Security Declaration]

Duly authorized to sign the bid for and on behalf of: [Name of Bidder]

Dated on _____ day of _____, 20__

[Corporate Seal (where appropriate)]

Self-Declaration by the bidder (In case bidder is Start-Up Entity)

Ref:

Date:

The Tender Evaluation Committee
Division,
ECIL.

Dear Sir,

Sub: Tender No. dated

We [Name & Address of the bidder], a Start-Up entity, hereby certify that:

- I. Our entity has been incorporated within 10 years,
- II. Our entity has not formed by splitting up or reconstruction of a business already in existence,
- III. Our entity has not exceeded Rs. 100 Crore turnover in any of the previous financial years.

Date:

Signature of the Director / proprietor

Seal of the Firm / Company

PRE-BID QUERY FORMAT

| SI.No. | Section No. | Page No. | Clause as per RFQ | Clarification sought |
|---------------|--------------------|-----------------|--------------------------|-----------------------------|
| | | | | |
| | | | | |
| | | | | |

(To be submitted as part of Techno-Commercial bid)
(On Company Letter-head)
(Along with supporting documents, if any)
Tender No.

Bidder's Name _____
[Address and Contact Details]

Bidder's Reference No. _____ Date.....

Eligibility Declarations

(Please tick appropriate boxes or cross out any declaration not applicable to the Bidder)

We hereby confirm that we are comply with all the stipulation of Tender Document clauses and declare as under and shall provide evidence of our continued eligibility to the Procuring Entity as may be requested:

1. **Legal Entity of Bidder:** _____
2. **OEM/ Manufacturer/ Agent/ Dealership Status:** _____
3. We are/ are not a JV _____
4. We solemnly declare that we (including our affiliates or subsidiaries or constituents):
 - (a) are not insolvent, in receivership, bankrupt or being wound up, not have our affairs administered by a court or a judicial officer, not have our business activities suspended and are not the subject of legal proceedings for any of these reasons;
 - (b) (including our Contractors/ subcontractors for any part of the contract):
 - (i) Do not stand declared ineligible/ blacklisted/ banned/ debarred by the Procuring Organisation or its Ministry/ Department from participation in its Tender Processes; and/ or
 - (ii) Are not convicted (within three years preceding the last date of bid submission) or stand declared ineligible/ suspended/ blacklisted/ banned/ debarred by appropriate agencies of Government of India from participation in Tender Processes of all of its entities, for offences mentioned in Tender Document in this regard. We have neither changed our name nor created anew "Allied Firm", consequent to the above disqualifications.
 - (c) We certify that we fulfil any other additional eligibility condition if prescribed in Tender Document.
 - (d) We have no conflict of interest, which substantially affects fair competition. The prices quoted are competitive and without adopting any unfair/ unethical/ anticompetitive means. No attempt has been made or shall be made by us to induce any other bidder to submit or not to submit an offer to restrict competition.
5. **Restrictions on procurement from bidders from a country or countries, or a class of countries under Rule 144 (xi) of the General Financial Rules 2017:**

We certify as under:

“We have read the clause regarding restrictions on procurement from a bidder of a country which shares a land border with India and on sub-contracting to contractors from such countries, and solemnly certify that we fulfil all requirements in this regard and are eligible to be considered. We certify that:

- (a) we are not from such a country or, if from such a country, we are registered with the Competent Authority (copy enclosed). and;*
- (b) we shall not subcontract any work to a contractor from such countries unless such contractor is registered with the Competent Authority.*

6. MSME Status:

Having read and understood the Public Procurement Policy for Micro and Small Enterprises (MSEs) Order, 2012 (as amended and revised till date), and solemnly declare the following:

- (a) We are – Micro/ Small/ Medium Enterprise/SSI/Govt. Deptt./PSU/ Others:.....
- (b) We attach herewith, Udyam Registration Certificate with the Udyam Registration Number as proof of our being MSE registered on the Udyam Registration Portal. The certificate is the latest up to the deadline for submission of the bid.
- (c) Whether Proprietor/ Partner belongs to SC/ ST or Women category. (Please specify names and percentage of shares held by SC/ ST Partners):.....

7. Start-up Status

We confirm that we are/ are not a Start-up entity as per the definition of the Department of Promotion of Industrial and Internal Trade – DPIIT.

8. Make in India Status:

Having read and understood the Public Procurement (Preference to Make in India PPP - MII) Order, 2017 (as amended and revised till date) and related notifications from the relevant Nodal Ministry/ Department, and solemnly declare the following:

(a) Self-Certification for the category of suppliers:

(Provide a certificate from statutory auditors/ cost accountant in case of Tenders above Rs 10 Crore for Class-I or Class-II Local Suppliers). Details of local content and location(s) at which value addition is made are as follows:

| | |
|-------------------------------|--|
| Local Content and %age | |
| Location(s) of value addition | |

Therefore, we certify that we qualify for the following category of the supplier (tick the appropriate category):

- Class-I Local Supplier/
- Class-II Local Supplier/
- Non-Local Supplier.

(b) We also declare that

- There is no country whose bidders have been notified as ineligible on a reciprocal basis under this order for an offered Goods, or

We do not belong to any Country whose bidders are notified as ineligible on areciprocal basis under this order for the offered Goods.

9. Penalties for false or misleading declarations:

We hereby confirm that the particulars given above are factually correct and nothing is concealed and undertake to advise any future changes to the above details. We understand that any wrong or misleading self-declaration would violate the Code of Integrity and attract penalties as mentioned in this Tender Document.

.....
(Signature with date)

.....
(Name and designation)

Duly authorized to sign bid for and on behalf of

.....
.....
[name & address of Bidder and seal of company]

PERFORMANCE BANK GUARANTEE (FORMAT)

To

M/s Electronics Corporation of India Limited

Communication Systems Group
ECIL (P.O), Hyderabad – 500 062

Bank Guarantee in respect of Contract No. _____ Dated _____ between M/s. Electronics Corporation of India Limited and _____ (Name of the Supplier).

This Deed of Guarantee made this _____ day of _____, Two Thousand _____ between _____ (Name of the Bank with address), (hereinafter called the 'Guarantor'), which expression shall unless repugnant to the context or meaning thereof be deemed to include its successors and assigns of the One Part, and

Electronics Corporation of India Limited, (a Government of India Enterprise), a Company incorporated under the Companies Act, 1956, having its Registered Office at Hyderabad – 500062, India (herein after called the 'Company'), which expression shall unless repugnant to the context or meaning thereof be deemed to include its successors and assigns, of the Other Part.

Whereas M/s _____ (Supplier/Contractor/Company Name and address) (herein after referred to as the Contractor) was awarded contract No. _____ dated _____ (hereinafter referred to as the Contract) by the Company for _____ (Scope of Work). And whereas the contract inter-alia, provides that the Supplier shall furnish Bank Guarantee to the Company a sum of Rs. _____ (Rupees _____ only) towards due and faithful performance of the contract in the form and manner specified therein covering the obligations of the contractor.

And whereas the contractor has approached the Guarantor and in consideration of the arrangement arrived at between the contractor and the Guarantor, the Guarantor has agreed to give Guarantee as hereinafter mentioned in favour of the Company.

Now this Deed witnesses as follows:

1. The Guarantor do hereby guarantee to the Company the due and faithful performance, observance or execution of the contract by the Supplier and further unconditionally and irrevocably undertake to pay to the Company without demur and merely on a demand, to the extent of Rs. _____ (Rupees _____) when claim is made by the Company on them for any loss, damage, costs, charges and expenses caused to or suffered by the Company by reason of the contractor making any default in the performance, observance or execution of the terms, conditions, stipulations or undertakings or any one of them as contained in The contract.
2. The decision of the Company whether any default has occurred or has been committed by the contractor in the performance, observance, discharge, execution of any of the terms, conditions, stipulations or undertakings or any one of them as contained in the contract and/or as to the extent of loss or damage costs, charges and expenses caused to or suffered by the Company by reason of the contractor making any default in the performance, observance or discharge of any of the terms, conditions, stipulations or undertakings or any one of them shall be conclusive and binding on the Guarantor, irrespective of the fact whether the contractor admits or denies the

faults or questions the correctness of any demand made by the Company in any Court, Tribunal or Arbitration proceedings or before any other Authority.

3. The Company shall have the fullest liberty without affecting in any way the liability of the Guarantor under this Guarantee from time to time to vary any of the terms and conditions of the contract or extend time of performance by the Supplier or to postpone for any time and from time to time any of the powers exercisable by it against the said contractor and either to enforce or forbear from enforcing any of the said terms and conditions governing the said contract and the Guarantor shall not be released from its liability under these presents and the liability of the Guarantor here under shall remain in full force and effect notwithstanding any exercise by the Company of the liberty with reference to the matters aforesaid or by reason of time being given to the contractor or any other forbearance, act or omission on the part of the Company or any indulgence by the Company to the said contractor or of any other matter or thing whatsoever which under the law relating to sureties, would, but for this provision have the effect of so releasing the Guarantor from its liability under this Guarantee.
4. The Guarantor further agrees that the Guarantee herein contained shall remain in full force and effect during the period that would be taken for the performance of the contract and its claims satisfied or discharged and till the Company certifies that the terms and conditions of the contract have been fully and properly carried out by the contractor and accordingly discharges this Guarantee subject to, however, that the Company shall have no claim under this Guarantee after ___ (months) from the date of completion of the contract, as the case may be, unless a notice of the claim under this Guarantee has been served on the Guarantor before the expiry of the said period in which case the same shall be enforceable against the Guarantor notwithstanding the fact that the same is enforced after the expiry of the said period.
5. The Guarantor undertakes not to revoke this Guarantee during this period it is in force except with the previous consent of the Company in Writing, and agree that any liquidation or winding up or dissolution or any change in the constitution of the contractor or the Guarantor shall not discharge the Guarantor's liability hereunder.
6. It shall not be necessary for the Company to proceed against the contractor before proceeding against the Guarantor and the Guarantee herein contained shall be enforceable against them notwithstanding any security, which the Company may have obtained or obtained from the contractor shall, at the time when the proceedings are taken against the Guarantor hereunder be outstanding or unrealized.
7. The Guarantor hereby declares that it has power to execute this Guarantee under its Memorandum and Articles of Association and the executants has full powers to do so on its behalf and the Power of Attorney dated _____, granted to him/her by the proper authority of the Guarantor.
8. This Guarantee is valid till _____ and the Company is entitled to lodge its claim on the Guarantor on or before _____ (additional 1 year). The Guarantor hereby undertakes to honour the said invocation without demur.

Witness:

Signed for and on behalf of the Bank (Guarantor)

- 1.
- 2.

Restrictions under Rule 144 (xi) of General Financial Rules 2017

1. The Provisions contained in Order (Public Procurement No.1) of DOE, Public Procurement Division, No. F.No.6/18/2019-PPD, dt. 23.7.2020 and as amended / clarified from time to time, shall be applicable to this tender.
2. The following clauses are to be treated as part of Instructions to Tenderers.
 - (a) Any bidder from a country which shares a land border with India will be eligible to bid against this tender only if the bidder is registered with the Competent Authority specified in Annex-I of Order (Public Procurement No.1) Dated 23.07.2020.
 - (b) "Bidder" (including the term 'tenderer', 'consultant' or 'service provider' in certain contexts) means any person or firm or company, including any member of a consortium or joint venture (that is an association of several persons, or firms or companies), every artificial juridical person not falling in any of the descriptions of bidders stated hereinbefore, including any agency branch or office controlled by such person, participating in procurement process.
 - (c) "Bidder from a country which shares a land border with India" for the purpose of this order means:-
 - (i) An entity incorporated, established or registered in such a country; or
 - (ii) A subsidiary of an entity incorporated, established or registered in such a country; or
 - (iii) An entity substantially controlled through entities incorporated, established or registered in such a country; or
 - (iv) An entity whose beneficial owner is situated in such a country; or
 - (v) An Indian (or other) agent of such an entity; or
 - (vi) A natural person who is citizen of such a country; or
 - (vii) A consortium or joint venture where any member of the consortium or joint venture falls under any of the above.
 - (d) The beneficial owner for the purpose of (iii) above will be as under:
 - (i) In case of a company or Limited Liability Partnership, the beneficial owner is the natural person(s), who, whether acting alone or together, or through one or more juridical person, has a controlling ownership interest or who exercises control through other means.

Explanation-

- a) "Controlling ownership interest" means ownership of or entitlement to more than twenty-five percent of shares or capital or profits of the company;
- b) "Control" shall include the right to appoint majority of the directors or to control the management or policy decisions including by virtue of their shareholding or management rights or shareholder's agreements or voting agreements.
- (ii) In case of a partnership firm, the beneficial owner is the natural person(s) who, whether acting alone or together, or through one or more juridical person, has ownership of entitlement to more than fifteen percent of capital or profits of the partnership;
- (iii) In case of an unincorporated association or body of individuals, the beneficial owner is the natural person(s) who, whether acting alone or together, or through one or more juridical person, has ownership of or entitlement to more than fifteen percent of the property or capital or profits of such association or body of individuals.
- (iv) Where no natural person is identified under (1) or (2) or (3) above, the beneficial owner is the relevant natural person who holds the position of senior managing official;
- (v) In case of a trust, the identification of beneficial owner(s) shall include identification of the author of the trust, the trustee, the beneficiaries with fifteen percent or more interest in the trust and any other natural person exercising ultimate effective control over the trust through a chain of control or ownership.

- (e) An agent is a person employed to do any act for another, or to represent another in dealings with third person.
- 3. A bidder is permitted to procure raw material, components, sub-assemblies etc. from the vendors from countries which shares a land border with India. Such vendors will not be required to be registered with the Competent Authority, as it is not regarded as "sub-contracting".
- 4. However, in case a bidder has proposed to supply finished goods procured directly / indirectly from the vendors from the countries sharing land border with India, such vendor will be required to be registered with the Competent Authority.

Format of Certificate for Tenders for Works under Rule 144 (xi) in the General Financial Rules (GFRs), 2017

To
Head, CD
ECIL,
Hyderabad.

DECLARATION BY AUTHORISED SIGNATORY OF THE FIRM

Dear Sir,

Ref: Your Tender No. _____ dated _____

I/We, the undersigned, _____ (full name), do hereby declare, in my capacity as _____ of M/s. _____ (name of bidder entity), that:

1. I have read the Orders (Public Procurement No. 1,2 &3) dt 23rd July 2020 & 24th July 2020 on the subject of Restrictions under Rule 144 (xi) of the General Financial Rule (GFRs), 2017 regarding restrictions on procurement from a bidder of a country which shares a land border with India.

2. I/we certify that M/s. _____ (name of bidder entity)

a) **is not from such a country.** I hereby certify that this bidder fulfils all requirements in this regard and is eligible to be considered. **OR,**

b) **is from such a country** (strike out whichever is not applicable), and has been registered with the Competent Authority. I hereby certify that this bidder fulfils all requirements in this regard and is eligible to be considered. [Where applicable, evidence of valid registration by the Competent Authority is attached)

3. I understand that the submission of incorrect data and / or if certificate / declaration given by M/s. _____ (name of bidder entity) is found to be false, this would be a ground for immediate termination and further legal action.

4. This declaration cum undertaking is executed by us through our Authorized signatory/ies after having read and understood the Office Memorandum and Order (Public Procurement No.1,2,3) dated 23rd and 24th July 2020 of Ministry of Finance, Department of Expenditure, Public Procurement Division, Government of India including the words defined in the said order which shall have the same meaning for the purpose of this Declaration cum Undertaking.

Executed at _____ On this the ____ day of _____

By Authorized Signatory
(Signature and Name)
Seal of the Bidder

*Note: Where applicable, evidence of valid registration by the Competent Authority shall be attached.

Public Procurement (Preference to Make In India), Order 2017
FORMAT

Local content Declaration & Self Certification as per the Government of India Order towards Public Procurement (preference to Make in India) vide Letter No. P-45021/2/2017-PP(BE-II), (revised) Dated.16.9.2020).

(TO BE PROVIDED ON Rs.100/- NON- JUDICIAL STAMP PAPER)

IN RESPECT OF RFQ No:

ISSUED BY:

I _____(Name of the Person(s),S/o, /D/o, W/o _____ at _____(Address), _____ working as _____(Designation and name of the firm/Company/ partnership/ Joint venture), and I have been authorized to sign the Declaration / Self- Certification on behalf of firm / Company/ Partnership/ Joint Venture do hereby solemnly affirm and declare as under: -

That I will agree to abide by the terms and conditions of the policy of Government towards Public Procurement (preference to Make in India) vide Letter No. P-45021/2/2017-PP(BE-II), (revised) Dated.16.9.2020.

That the information furnished hereinafter is correct to the best of my knowledge and belief and I undertake to produce relevant records before the procuring authority or any authority so nominated by the Department of Atomic Energy [name of the Ministry/Department], Government of India for the purpose of assessing the local content.

That the local content for all inputs which constitute the _____ products has been verified by me and I am responsible for the correctness of the claims made therein.

That in the event of the local content of the product mentioned herein is found to be incorrect and not meeting the prescribed local content norms, based on the assessment of an authority so nominated by the Department of Atomic Energy [name of the Ministry/Department], Government of India for the purpose of assessing the local content. _____ [name of the firm/entity] will be disqualified from any Government tender for a period upto two years. In addition, _____ [name of the firm/entity] will bear all costs of such an assessment.

That I have complied with all conditions referred to in the Notification No. Public Procurement (preference to Make in India) vide Letter No. P-45021/2/2017-PP(BE-II), (revised) Dated.16.9.2020., wherein preference to domestically manufactured _____ products in Government procurement is provided and the procuring authority is hereby authorized to forfeit and adjust our EMD and other security amount towards such assessment cost and _____ [name of the firm/entity] undertake to pay the balance, if any, forthwith.

_____ [name of the firm/entity] agree to maintain the following information in its record for a period of 8 years and shall make this available for verification to any statutory authorities. Further I am submitting the following details –

- i. Name and details of the Domestic Manufacturer/Bidder/Local Supplier (Registered office, Manufacturing unit, location, nature of legal entity).
- ii. Date on which this certificate is issued.
- iii. Product for which the certificate is produced.
- iv. Procuring agency to whom the certificate is furnished.
- v. Percentage of local content claimed and whether it meets the threshold value of local content prescribed. Details to be provided.

Proforma to calculate Local Content

| Cost Component | &to the Total Cost of Production | | |
|-----------------------|----------------------------------|--------------------|-------|
| | Domestic Component | Imported Component | Total |
| | A | B | C=A+B |
| Cost of Goods used | | | |
| Cost of Services used | | | |
| Factory Overheads | | | |
| Total Production Cost | | | |

- vi. Name and contact details of the unit of the manufacturer(s) at which the local value addition is made.

Signed by me at _____ on _____ /2024

Authorized signatory
(Name of the Firm entity)

AUDITOR / ACCOUNTANT'S CERTIFICATE FOR LOCAL CONTENT

The Board of Directors

_____ Limited

I/We _____ (name of the Auditor/Accountant's Firm), having Registration Number _____ and Registered Address at _____ (Full address) represented for signature of this Certificate by _____ (Name and designation of Authorized Representative), hereby certify that: -

1. This report is issued in accordance with the terms of our engagement letter dated _____ with _____ (name of the company).

2. The company has provided self-certification affidavit certifying that the local content percentage _____ % (in numbers and words) reflected in the certificate furnished & enclosed by _____ (name of the company) during the manufacture/supply of _____ (name of the product) has been/would be [strike words not applicable] achieved.

3. The statement on calculation of local content percentage has been prepared by the Company's management. The management is responsible for the preparation and maintenance of all accounting and other relevant supporting records and documents.

4. I/We understand that this certificate is being produced by _____ (name of the company) for the purpose of availing purchase preference under the policy of _____ [name of the Ministry/Department] Government of India issued vide Notification No. Public Procurement (preference to Make in India) vide Letter No. P-45021/2/2017-PP(BE-II), (revised) Dated.16.9.2020, as amended.

5. I/We understand that this certificate is being submitted as part the company's Offer against the tender enquiry Doc. No. _____ issued by _____ (name of the tender issuing entity) in respect of supply of _____ (name of the products) to _____ (name of procuring entity). OR

I/We understand that this certificate is being submitted as part the company's supply of _____ (name of the products) to _____ (name of procuring entity) vide Invoice no. _____ dated _____ against the Contract No. _____ dated _____.

6. I/We have examined the information, records and books of Accounts presented before me/us by _____ (Name and complete address of the company) and provide a limited assurance that nothing has come to our attention that causes us to believe that the company has not complied/would not comply [strike words not applicable] with the mandatory minimum local content requirements as stated in the Purchase Preference Policy or that the calculations given are arithmetically inaccurate. As per these calculations, the local content as a proportion of the total value, in percent is _____ (percentage of local content) as reflected in the certificate furnished & enclosed

by _____ (name of the company) for the manufacture/ supply of
_____ (name of the product).

7. I/We conducted our examination in accordance with the Auditing/Cost Auditing* Standards and Guidance Manual for Audit Quality* issued by the Quality Review Board of the Institute of Cost/Chartered* Accountants of India. The Guidance Note requires that we comply with the ethical requirements of the Code of Ethics issued by the Institute of Cost/Chartered* Accountants of India. * Strike-off whichever not applicable

8. For identification purposes, I/We have initialed the self-certification affidavit as prepared & signed by the company enclosed.

9. The report is addressed to the company solely for the purpose of enabling it to comply with the requirements of the Tender Document/Supply Contract [strike words not applicable] and should not be used, referred to or distributed for any other purpose or to any other party without our prior written consent.

Authorized Auditor/ Accountant
(Name /Name of Firm)
Membership Number / Registration Number
UDINNumber:

Seal of the Firm
Date: